Table of Contents

1.0 Introduction.....	3
2.0 Five-Nines Availability.....	4
2.1 ShoreTel vs. Other IP PBXs	5
2.2 ShoreGear’s Demonstrated Availability	7
2.3 Predicted and Demonstrated MTBF	7
2.4 The Bathtub Curve.....	8
2.5 Mean Time To Repair (MTTR)	9
2.6 When More is More Trouble	10
2.7 Comparing Five-Nines Configurations.....	11
2.8 Five-Nines Availability Review	12
3.0 N+1 Redundancy.....	13
3.1 No Single Point of Failure	13
3.2 Redundancy Review	14
4.0 Network Reliability.....	15
4.1 Network Reliability Review	17
5.0 Applications Reliability	19
5.1 Application Servers.....	19
5.2 Fallback Mechanisms.....	21
5.3 Reliable Applications Review.....	22
6.0 Soft Reliability	23
6.1 Maintenance and Availability	23
6.2 Network Quality.....	24
6.3 Software Reliability Review	25
7.0 Conclusion	27

2.1 ShoreTel vs. Other IP PBXs

Other IP PBXs can achieve five-nines of availability, but they do so by using redundancy and thus adding to the cost and complexity of the solution. The base units of competing IP telephony systems offer significantly lower availability than ShoreGear units, because they lack the unique architecture and design of the ShoreTel system.

ShoreTel Call Control Architecture

All of the major IP PBX vendors use a call control server to set up phone calls and provide telephony features. The most common method is to use a centralized call control server that provides dial tone for all phones and trunks, as shown in the figure below:

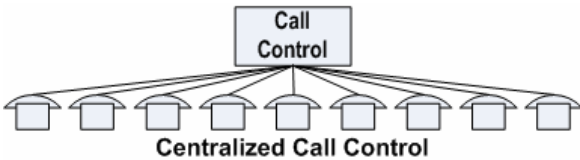

The diagram shows a single box labeled 'Call Control' at the top. Below it, eight lines radiate downwards to eight separate house-shaped icons representing phones. The text 'Centralized Call Control' is centered below the icons.

In distinct contrast, ShoreTel uses a distributed call control model. A portion of the end points are handled by each call control server as illustrated in the Distributed Call Control figure below:

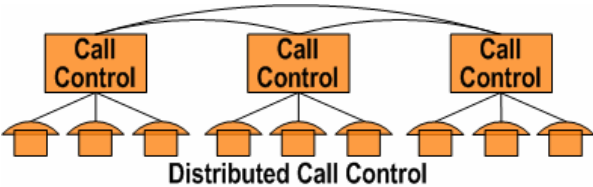

The diagram shows three boxes labeled 'Call Control' arranged horizontally. Below each box are three house-shaped icons representing phones. Lines connect each 'Call Control' box to its respective three phones. A curved line also connects the three 'Call Control' boxes at the top. The text 'Distributed Call Control' is centered below the icons.

Call control is provided by each ShoreGear switch comprising a ShoreTel system. In competing IP telephony systems, vendors implement call control on a separate computer system. This computer system is typically embedded in the IP PBX chassis, but some vendors put it in a separate box.

The modular ShoreTel architecture allows for ShoreGear switches to be designed as small, simple, and reliable hardware. In contrast, most competitors use a chassis-based design of the type illustrated by the “Classic Chassis” figure below.

